

TOWN OF WAPPINGER



BUILDING DEPARTMENT
20 MIDDLEBUSH ROAD
WAPPINGERS FALLS, NY 12590-0324
(845) 297-6256 FAX: (845) 297-0579

PERMIT APPLICATION FOR CONNECTING TO TOWN WATER

Fees:

Residential

\$150 application fee
PLUS Water Meter Fee

Commercial

\$250 application fee
PLUS Water Meter Fee
(some commercial properties
will require special meter sizes)

Water Meter Fees:

¾" Meter - \$267.53

1" Meter - \$456.75

Application and meter fees must
be paid separately. Cash or
Check only.

*****Please contact Building Department PRIOR to submitting this application to determine water connection eligibility. Eligibility will be confirmed by Town Engineer and Camo Pollution Control. A determination will need to be made as to if/what infrastructure is available for connection.*****

If the property is NOT in an approved water district AND an emergency situation arises, district expansion or tenancy agreement approved by the Town Board will be required. Please see below for buy-in fees associated with such process. A building permit will still need to be obtained after approvals.

§ 236-6. Buy-in fees to sewer and water districts

Water districts.

(a)

Nonresidential parcels. The capital buy-in fee for out-of-district nonresidential parcels to a water district shall be a sum equal to \$10 per gallon of estimated daily design flow, as determined by a competent engineer and confirmed by the Engineer to the Town.

(b)

Residential parcels.

[1]

For single-family residential parcels with no more than four bedrooms per residential unit, the average daily usage shall be deemed to be 320 gallons per day, equaling a capital buy-in fee of \$3,200.

[Amended 4-9-2012 by L.L. No. 7-2012]

[2]

For each additional bedroom, the presumptive daily usage will increase by 100 gallons per day, with an additional capital buy-in fee of **\$1,000 per bedroom over four bedrooms.**

If property is determined to be in an existing water district the following will be required to be submitted along with this application:

-Plan/drawing showing type of piping, routing, well disconnections, details for materials and trenching, etc.

Attached Town specifications for residential connection MUST be adhered to.

-Proof of Workers' Compensation and Disability insurance for contractor. The Town of Wappinger requires proof of Workers' Compensation (C105.2 or 26.3) and Disability (DB120.1) insurance. The application for a Certificate of Attestation of Exemption, Form CE-200, from Workers' Compensation and/or Disability and Paid Family Leave Benefits coverage may only be completed by homeowners doing their own work, entities with no employees and/or out-of-state entities obtaining a contract or license in which all the work is being performed outside of New York State.

-If the connections disturb a state, county or town road right of way, highway work permit will be required from the entity with jurisdiction

- Upon issuance of the permit to connect, we require a meeting with Camo Pollution & the contractor to ensure the point of connection and any other construction issues are clear.

-Work must be inspected by Building Department or Camo Pollution

****ALL FEES ARE NON-REFUNDABLE****

****CALL 811 BEFORE YOU DIG****

TOWN OF WAPPINGER BUILDING DEPARTMENT

20 Middlebush Road, Wappingers Falls, N.Y. 12590

telephone: 845-297-6256 fax: 845-297-0579

APPLICATION FOR BUILDING PERMIT

APPLICATION TYPE: Residential Commercial Multiple Dwelling
 New Construction Commercial Multiple Dwelling
 Renovation/Alteration Multiple Dwelling

ZONE: _____ **DATE:** _____
APPL #: _____ **PERMIT #** _____
GRID: _____

APPLICANT NAME: _____

ADDRESS: _____

TEL #: _____ **CELL:** _____ **FAX #:** _____ **E-MAIL:** _____

NAME OWNER OF BUILDING/LAND: _____

***PROJECT SITE ADDRESS*:** _____

MAILING ADDRESS: _____

TEL #: _____ **CELL:** _____ **FAX #:** _____ **E-MAIL:** _____

BUILDER/CONTRACTOR DOING WORK:

COMPANY NAME: _____

ADDRESS: _____

TEL #: _____ **CELL:** _____ **FAX #:** _____ **E-MAIL:** _____

DESIGN PROFESSIONAL NAME:

TEL #: _____ **CELL:** _____ **FAX #:** _____ **E-MAIL:** _____

APPLICATION FOR: _____

SETBACKS: FRONT: _____ REAR: _____ L-SIDEYARD: _____ R-SIDEYARD: _____

SIZE OF STRUCTURE: _____

ESTIMATED COST: _____ **TYPE OF USE:** _____

NON-REFUNDABLE APPL. FEE: _____ **PAID ON:** _____ **CHECK #** _____ **RECEIPT #:** _____

BALANCE DUE: _____ **PAID ON:** _____ **CHECK #** _____ **RECEIPT #:** _____

APPROVALS:

ZONING ADMINISTRATOR:
 Approved Denied **Date:** _____

FIRE INSPECTOR:
 Approved Denied **Date:** _____

Signature of Applicant

Signature of Building Inspector

Print Name or Company Name(if applicable)

TOWN OF WAPPINGER



BUILDING DEPARTMENT
20 MIDDLEBUSH ROAD
WAPPINGERS FALLS, NY 12590-0324
(845) 297-6256
FAX: (845) 297-0579

OWNER CONSENT FORM

BUILDING PERMIT # _____ APPLICATION # _____

SITE LOCATION: _____

GRID: # _____

Name of APPLICANT: _____

(Person PHYSICALLY coming in to apply)

~ CERTIFICATION ~

NOTICE TO APPLICANTS: 240-109 Certificate of Occupancy

It shall be unlawful for a building owner to use or permit the use of any building or premises or part thereof hereafter created, erected, changed, converted or enlarged, wholly or partly, in its use or structure *until a Certificate of Occupancy shall have been issued by the Building Inspector and the Zoning Administrator.*

I, _____, owner of the land/site/building hereby give my permission for the Town of Wappinger to approve or deny the above application in accordance with local and state codes and ordinances. I understand that this permit will not be closed out unless all proper inspections are completed which can include the building inspector having access to the interior of my residence/business. If this permit is not issued a certificate before the expiration date it will remain as a violation on my property until it is closed out. After the expiration date a new application and the permit fee will have to be submitted/paid again in order to close out the permit. I understand, as the land/site/building owner, that I am ultimately responsible for the closure/completion of the work described on this permit.

FAILURE TO COMPLY MAY RESULT IN COURT PROCEEDINGS.

Date

Owner's Signature

Owner's Telephone Number

Print Name

Print Owner's Address

FOR OFFICE USE ONLY

Code Enforcement Official: _____

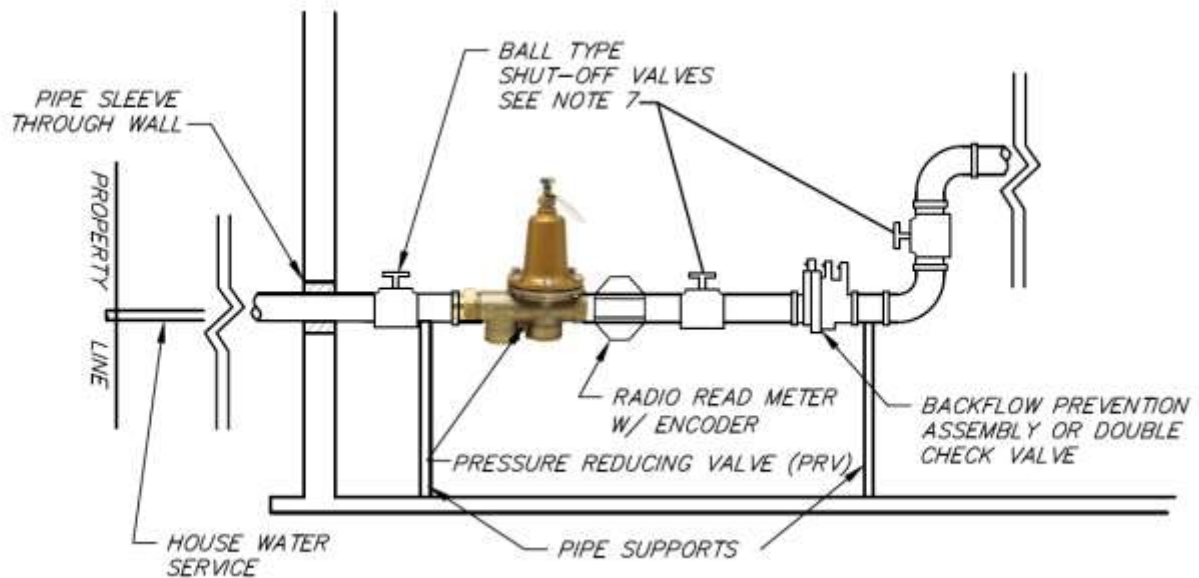

INSTALLATION NOTES:

1. ALL MATERIALS USED SHALL CONFORM TO THE REQUIREMENTS OF THE NEW YORK STATE PLUMBING CODE.
2. INSIDE PIPE JOINTS SHALL BE SOLDERED OR FLARED CONNECTIONS ONLY.
3. NO FITTINGS SHALL BE INSTALLED ON THE LINE BETWEEN THE HOUSE AND THE CURB VALVE UNLESS THE LENGTH OF PIPE INSTALLED EXCEEDS 100 FEET.
4. UTILITY LINES, INCLUDING SEWER AND WATER SERVICES, MUST BE SEPARATED BY A MINIMUM OF 10' UNLESS BENCHED IN ACCORDANCE WITH N.Y.S. PLUMBING CODE. BENCHED PIPES SHALL HAVE 18" MINIMUM HORIZONTAL AND VERTICAL SEPARATION. WATER LINES SHALL ALWAYS BE INSTALLED ABOVE SANITARY SEWER LINES.
5. BACKFLOW PREVENTION ASSEMBLIES SHALL BE PERIODICALLY TESTED PER TOWN CODE SECTIONS 2503.7.1 AND 2503.7.2. TEST RESULTS SHALL BE PROVIDED TO THE TOWN. PROPERTY OWNERS SHALL BE RESPONSIBLE FOR TESTING OF ALL BACKFLOW PREVENTION DEVICES AND SHALL SUBMIT TEST RESULTS TO THE TOWN UPON REQUEST.
FOR RESIDENTIAL USE: WATTS SERIES 7 RESIDENTIAL DUAL CHECK VALVE OR EQUAL.
FOR COMMERCIAL USE: BACKFLOW PREVENTION SHALL BE AS PER THE TOWN APPROVED SITE/PROJECT PLAN AND SHALL INCLUDE A STRAINER.
6. COMMERCIAL WATER SERVICE LINES SHALL BE CONSTRUCTED TO MEET THE REQUIREMENTS SHOWN HEREON AT MINIMUM. ADDITIONAL REQUIREMENTS FOR EQUIPMENT OR CONSTRUCTION SHALL BE AS INDICATED ON THE APPROVED SITE PLAN.
7. SHUT OFF VALVES SHALL BE ¼ TURN BALL VALVES ONLY.
8. CURB VALVE SHALL HAVE STAINLESS STEEL ROD.
9. PROPERTY OWNER SHALL BE SOLELY RESPONSIBLE FOR MAINTENANCE AND/OR REPLACEMENT OF THE EXISTING WATER SERVICE PIPE AND COMPONENTS THAT ARE INSTALLED ON THEIR PRIVATE PROPERTY. (E.G. FROM THE CURB VALVE TO AND WITHIN ANY DWELLING OR STRUCTURE ON THE PROPERTY.) TENANTS TO THE SYSTEM AND COMMERCIAL USERS MAY HAVE ADDITIONAL RESPONSIBILITIES WHERE SPECIFIED IN SEPARATE COVENANTS OR APPROVALS WITH THE TOWN. THE TOWN SHALL BE RESPONSIBLE FOR OPERATION AND MAINTENANCE OF THE WATER SERVICE LINE IN THE PUBLIC RIGHT OF WAY, FROM THE MAIN TO THE CURB VALVE.
10. A PERMIT SHALL BE OBTAINED BEFORE ANY CONSTRUCTION ACTIVITY MAY BEGIN. THE TOWN WATER SYSTEM OPERATOR AND THE BUILDING DEPARTMENT MUST BE NOTIFIED IN ADVANCE OF TAPPING THE TOWN WATER MAINS.
11. IF THE WATER SERVICE PIPING PRESSURE EXCEEDS 60-PSI, THEN A PRESSURE REDUCING VALVE, WITH A MINIMUM WORKING PRESSURE OF 250 PSI, BRONZE BODY, STAINLESS STEEL STRAINER AND DESIGN OUTLET PRESSURE OF 60-PSI SHALL BE PROVIDED WITH THE WATER SERVICE. THE PRESSURE REDUCING VALVE SHALL BE WATTS OR APPROVED EQUAL.

 <p>9 ELKS LANE POUGHKEEPSIE, NEW YORK 12601 TEL (845) 454-3411 FAX (845) 473-1962 CPLteam.com ARCHITECTURE • ENGINEERING • PLANNING</p>	REV. No.	DESCRIPTION	DATE	BY	
	TOWN OF WAPPINGER				
	TOWN OF WAPPINGER		DUTCHESS COUNTY, NY		
TYPICAL RESIDENTIAL WATER SERVICE PIPING SYSTEM					
DATE	SCALE	DESIGNED BY: JFL	FILE No.		
01-06-21	N.T.S.	DRAWN BY: GS	W21000.02		
		CHECKED BY: RJG			
				DWG 1-1	

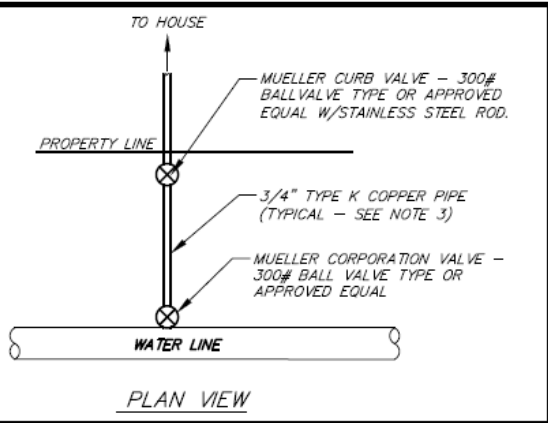
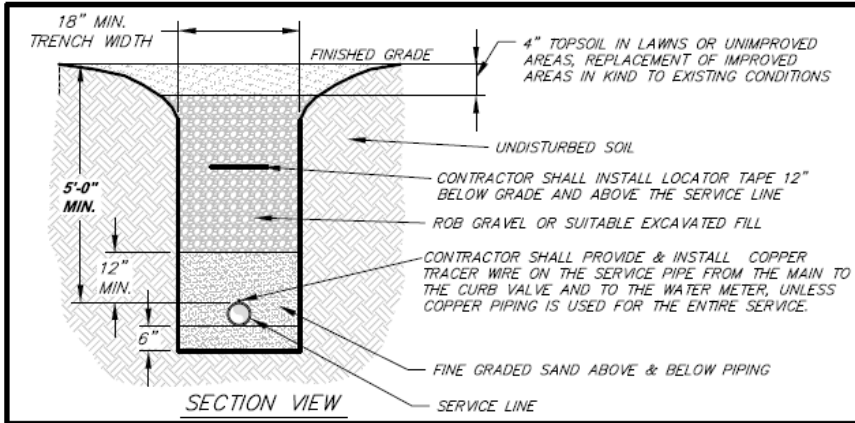

INSTALLATION NOTES:

1. ALL MATERIALS USED SHALL CONFORM TO THE REQUIREMENTS OF THE NEW YORK STATE PLUMBING CODE.
2. THE FOLLOWING GUIDELINES MUST BE CONFORMED TO:
 - A. THE ENTIRE TRENCH SHALL BE EXCAVATED BEFORE ANY PIPE IS LAID
 - B. THE TRENCH SHALL BE GRADED WITH A MINIMUM OF 6" OF SAND AS SHOWN. THIS LAYER SHALL THEN BE PROPERLY COMPACTED.
 - C. THE PIPE MAY THEN BE LAID.
 - D. A FINE GRADED SAND MUST BE THEN PLACED AROUND THE PIPE AND COMPACTED TO PROPERLY SUPPORT THE PIPE.
 - E. THE TRENCH MUST THEN BE FILLED TO A POINT 1' ABOVE TO TOP OF THE PIPE WITH SAND. THIS LAYER MUST BE THOROUGHLY COMPACTED WITH A MECHANICAL TAMPER.
 - F. THE REMAINDER OF THE TRENCH MAY THEN BE FILLED TO GRADE WITH RUN OF TRENCH MATERIAL.
3. PIPE USED IN WATER SERVICE CONNECTIONS SHALL BE TYPE "K" COPPER TUBING OR AS APPROVED IN THE N.Y.S. PLUMBING CODE, SECTION 605. IF PLASTIC PIPE IS USED FOR THE WATER SERVICE, IT MUST BEAR THE APPROVAL CODE OF AWWA C901, AND #10 WIRE SHALL BE RUN FROM UP THE CURB VALVE THROUGH THE FOUNDATION TO THE METER LOCATION INSIDE OF THE BUILDING.
4. MINIMUM COVER OVER THE PIPE WILL BE 5'-0" UNLESS INSULATED AGAINST FROST.
5. ALL DITCHES ARE TO BE DEWATERED BEFORE ANY PIPE IS LAID.
6. THE PIPE SHALL BE INSPECTED PRIOR TO ANY BACKFILLING.
7. FOR TESTING, WATER LINES SHALL BE TURNED ON AT THE CURB VALVE BY CAMO POLLUTION CONTROL AND INSPECTED FOR LEAKS BY THE TOWN BUILDING DEPT.
8. BEFORE ISSUANCE OF A C.O., MEASUREMENTS BETWEEN THE CURB VALVE BOX COVER AND THE HOUSE CORNERS SHALL BE SUBMITTED TO THE TOWN.
9. ALL FITTINGS TO BE FLARED OR SOLDERED PIPE CONNECTIONS.

CONSTRUCTION NOTE:

UTILITY LINES, INCLUDING SEWER AND WATER SERVICES, MUST BE SEPARATED BY A MINIMUM OF 10' UNLESS BENCHED IN ACCORDANCE WITH N.Y.S. PLUMBING CODE. BENCHED PIPES SHALL HAVE 18" MINIMUM HORIZONTAL AND VERTICAL SEPARATION. WATER LINES SHALL ALWAYS BE INSTALLED ABOVE SANITARY SEWER LINES.



9 ELKS LANE
POUGHKEEPSIE, NEW YORK 12601
TEL (845) 454-3411
FAX (845) 473-1962
CPLteam.com
ARCHITECTURE • ENGINEERING • PLANNING

REV. No.	DESCRIPTION	DATE	BY
TOWN OF WAPPINGER			
TOWN OF WAPPINGER		DUTCHESS COUNTY, NY	
TYPICAL RESIDENTIAL WATER SERVICE CONNECTION			
			DWG 1-1

DATE	SCALE	DESIGNED BY: JFL	FILE No.
01-06-21	NTS	DRAWN BY: GS	W21000.02
		CHECKED BY: RJG	